



Micro Commercial Components

THROUGH HOLE - AXIAL LEADED

Through Hole Package Quantity

Case Style	Available Packaging (pcs)				
	Bulk			13" Tape & Reel	Ammo Pack
	Box/Bag Qty	Tube Qty	Tray Qty	Qty	Qty
A-405				5000	
DB-1	2500	50			
DO-15	500			4000	3000
DO-201AD	500			1200	1200
DO-201AE	500			1200	1200
DO-35	10000			10000	
DO-35G	10000			10000	
DO-41	1000			5000	5000
DO-41G	1000			5000	
GBJ	750	15			
GBP	2100	35			
GBPC	50				
GBU	1000	20			
ITO-220AB	1000	50			
ITO220AC	1000	50			
KBJ	1000	20			
KBPL	1000				
MB-1	5000	100			
MB-35	50				
MB-35D	50				
MB-35W	50				
MB-50W	50				
MP-50	50				
MP-50W	50				
PB-10	200				
PB-3	200				
PB-6	200				
PRESSFIT	100				
R-1				5000	
R-3	500			3000	
R-6	200			500	450
RA	1000				
RB-15	1000				
RS-4L	400		100		
SRA	1000				
TO-126	1000	50			
TO-18	100				
TO-220	1000	50			
TO-220AB	1000	50			
TO-220AC	1000	50			
TO-39	50				
TO-92	1000				2000
TO-92L	1000				2000
TO-92MOD	500				
TO-92S	3000				2000
WOM	1000				

- Please note that these are packing minimums only and do not reflect order minimums. For minimum order quantities please contact the factory.

THROUGH HOLE - AXIAL LEADED

Taping Specifications

Description	Dimension	Case Style	Specification(mm)
Component Pitch	A	DO-15, DO-35, DO-41, DO-7, A-405, R-3, R-1	5.0±0.5
		5KP, DO-201AD, R-6	10.0±0.5
Inside Tape Spacing	B	All	52.4±1.5
Lead To Lead Eccentricity	[C ₁ - C ₂]	All	1.0 Max.
Lead Extension	D	All	0.5 Max.
Lead Bending	E	All	1.2 Max.
Cumulative Pitch	G	All	1.5 per 10 pitch
Exposed Adhesive	H	All	0.8 Max.
Tape Width	J	All	6.0±0.4
Tape Leader	Beginning and end of reel or ammo pack		300.0 Min.
Empty Spaces	Consecutive missing components not allowed		<0.1%
Polarity Marking	All polarized components shall be oriented in the same direction. The cathode tape shall be colored and the anode tape shall be white or light beige.		

Dimensions apply to both sides of the reel

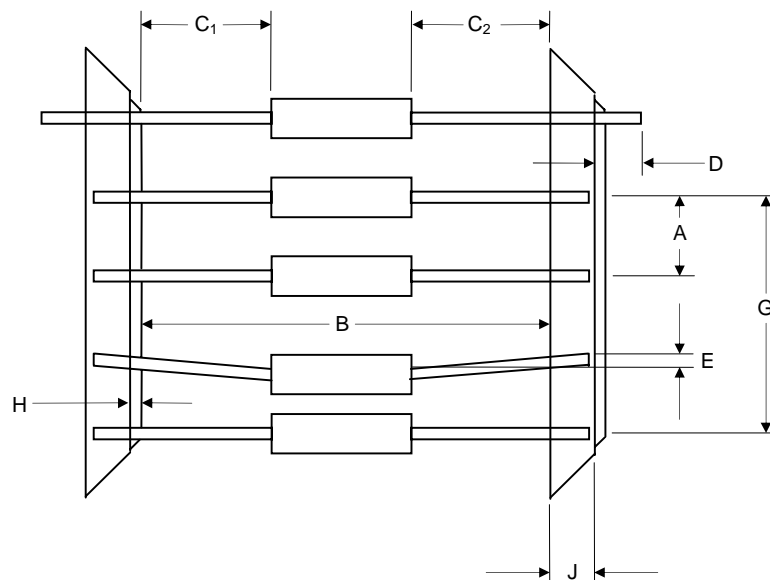

THROUGH HOLE - AXIAL LEADED

Reel Dimensions

Description	Dimension	Specification(mm)
Reel Diameter	A	330 335 (DO-35 Only)
Core Diameter (Outside Dimension)	B	16.6±0.4
Arbor Hole Diameter	C	85.7±0.3
Reel Width	D	79.0±1.0

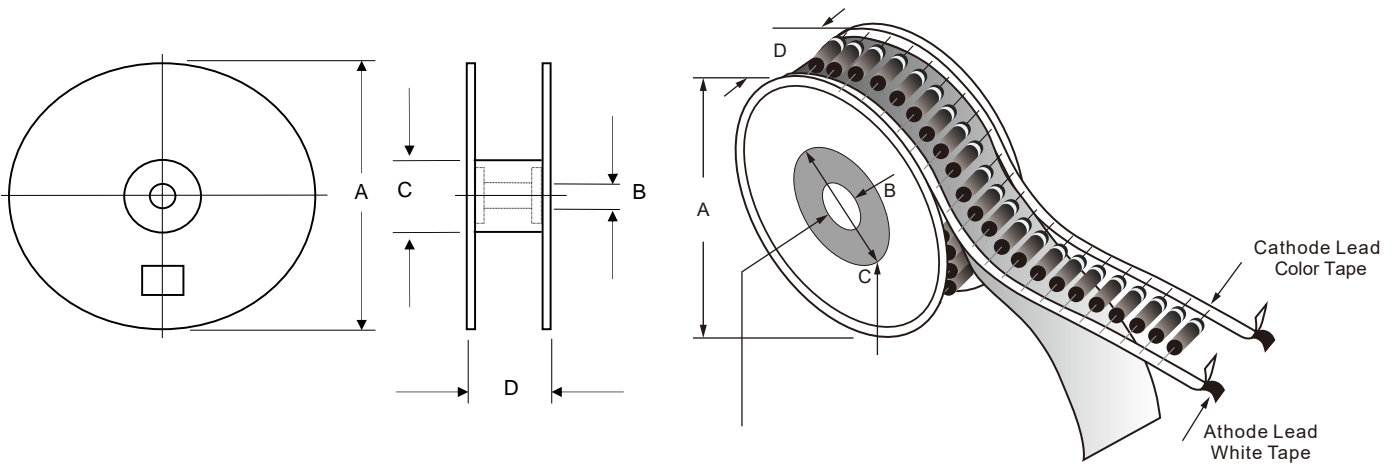

Ammo Pack Dimensions

Description	Dimension	Specification(mm typical)
Length	A	260
Width	B	75
Height	C	140

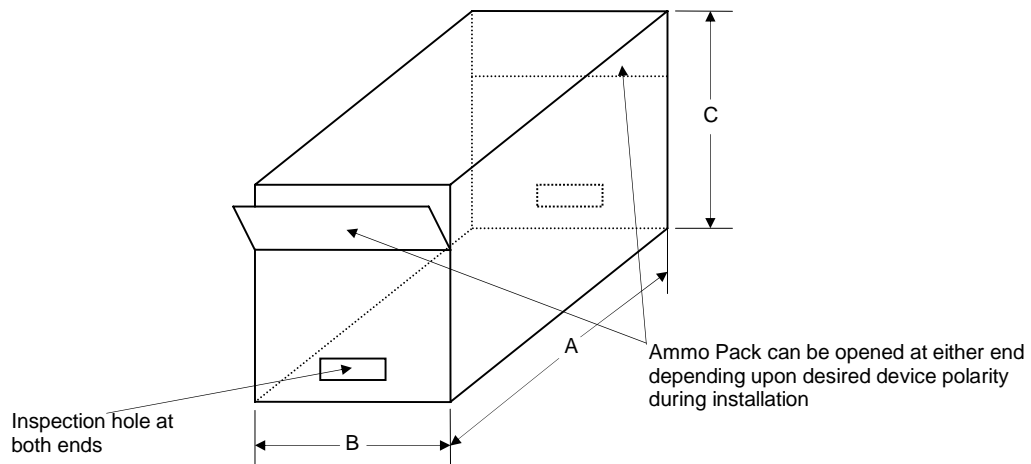

THROUGH HOLE - TO-92

Taping Specifications

Description	Dimension	Specification(mm)
Front To Rear Deflection	A	0±1.0
Left To Right Deflection	B	0±1.0
Feed Hole Diameter	C	4.0±0.2
Component Lead Pitch	D	2.5±0.3
Feed Hole To Bottom Of Component	E	21.0 Max.
Height Of Seating Plane	G	16±0.5
Height Of Feed Hole Location	H	9.0 ^{+0.8} _{-0.5}
Feed Hole Pitch	J	12.7±0.3
Center Of Seating Plane Location	K	6.35±0.5
Total Taped Package Thickness	M	1.5 Max.
Carrier Tape Width	N	18.0 ^{+1.0} _{-0.5}
Adhesive Tape Width	P	6.0±0.5
Adhesive Tape Position	R	1.0 Max.
Feed Hole Pitch Tolerance	---	0±1.0 over 20 pitch
Empty Places in Tape	---	0.1% non-consecutive

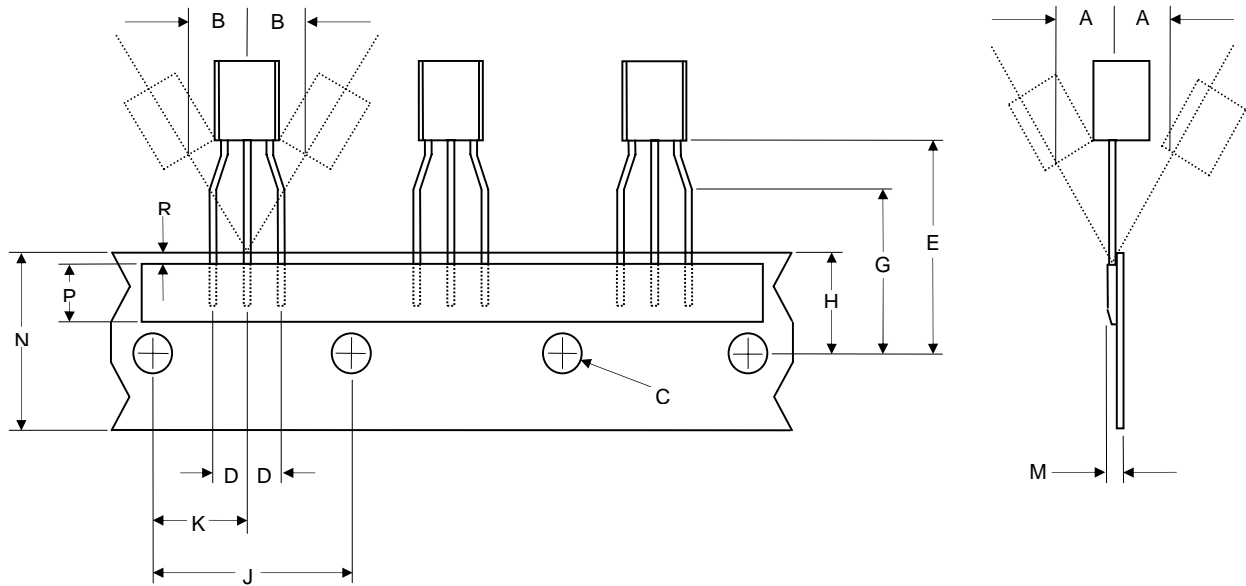

THROUGH HOLE - TO-92S

Taping Specifications

Description	Dimension	Specification(mm)
Front To Rear Deflection	A	0±1.0
Left To Right Deflection	B	0±1.0
Feed Hole Diameter	C	4.0±0.2
Component Lead Pitch	D	2.5±0.3
Feed Hole To Bottom Of Component	E	21.0 Max.
Height Of Seating Plane	G	16±0.5
Height Of Feed Hole Location	H	9.0±0.5
Feed Hole Pitch	J	12.7±0.2
Center Of Seating Plane Location	K	6.35±0.3
Total Taped Package Thickness	M	1.52±0.2
Carrier Tape Width	N	18.0 ^{+1.0} _{-0.5}
Adhesive Tape Width	P	6.0±0.5
Adhesive Tape Position	R	1.0 Max.
Feed Hole Pitch Tolerance	---	0±1.0 over 20 pitch
Empty Places in Tape	---	0.1% non-consecutive

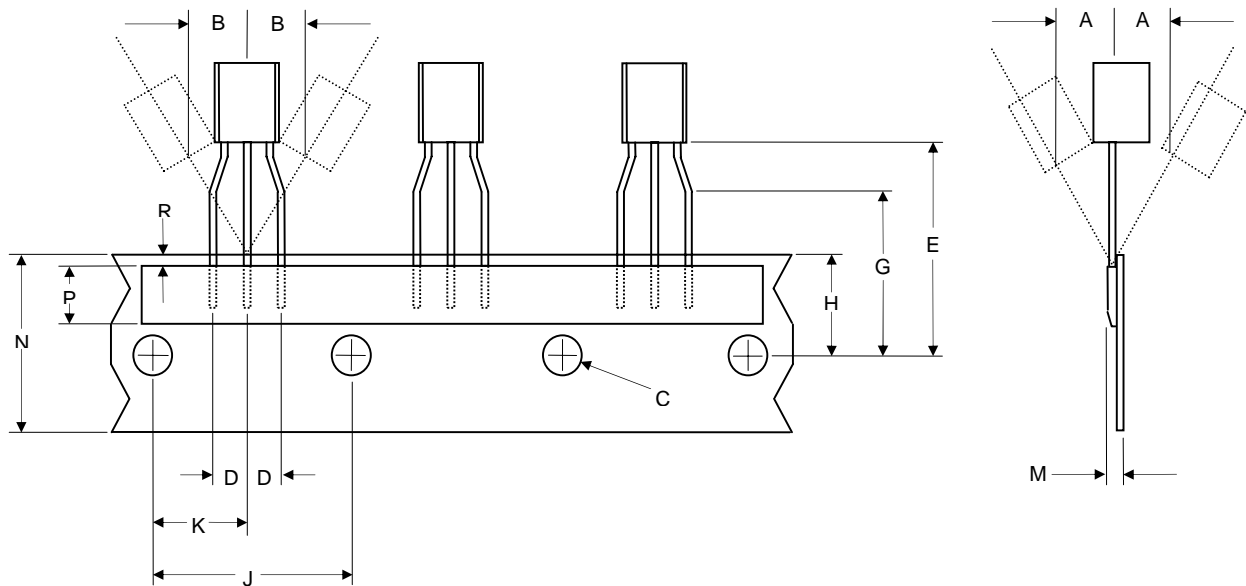

THROUGH HOLE - TO-92

Ammo Pack Specifications

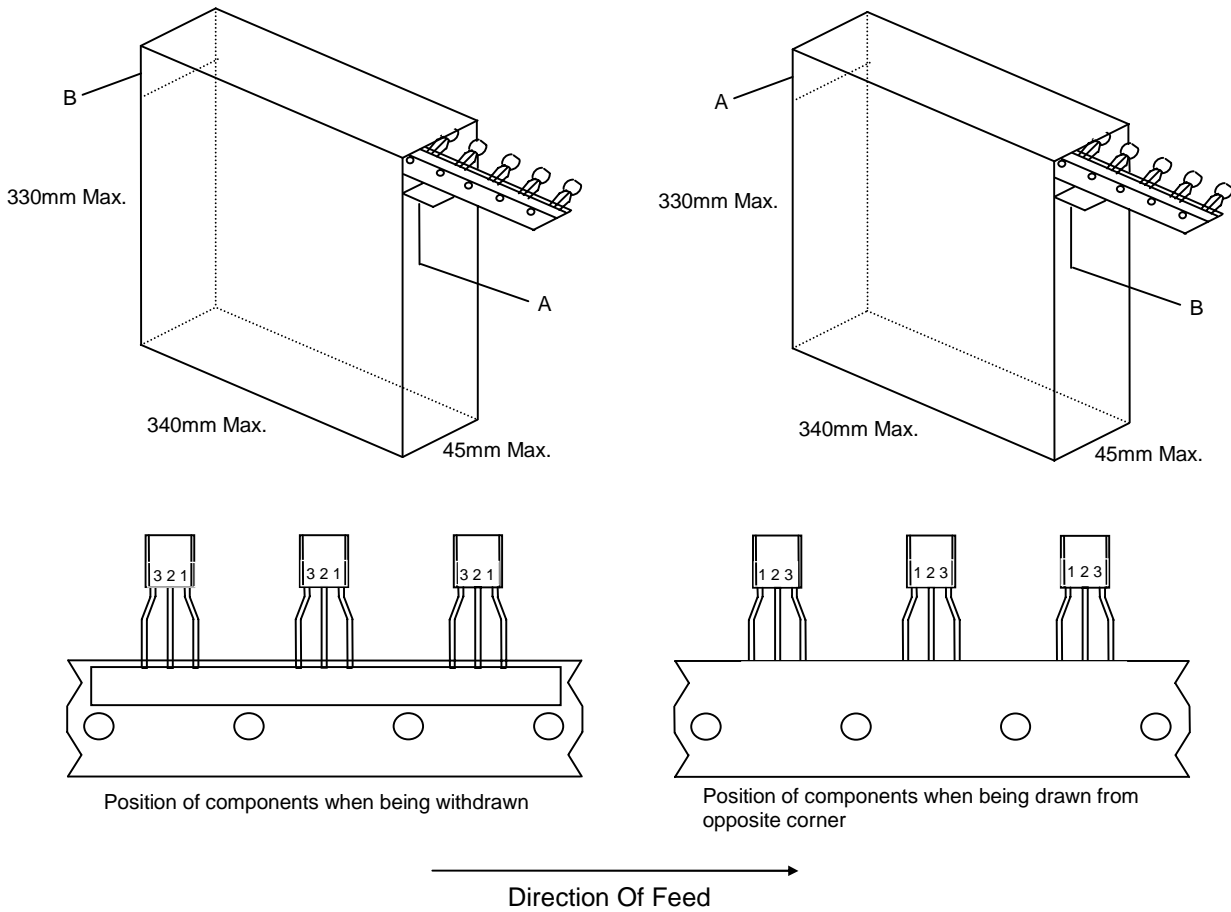

- Notes:
- 1) The carrier tape consists of a cardboard strip with sprocket holes. The pins of the transistors are secured radially to the carrier tape with a heat seal type tape.
 - 2) The tape can be taken from either of the two opposite corners, depending on the desired pin sequence.
 - 3) The label will include a minimum of the part number, quantity and date code.
 - 4) Each ammo pack consists of layers of 25 devices each folded in a concertina fashion. One component is missing at the end of each layer. Each position is identified by means of a double perforation across the tape. The tape is folded at the perforations.

SURFACE MOUNT

Minimum Package Quantities

TYPE	TAPE SIZE (mm)	BULK/TUBE QUANTITY	7 INCH REEL QUANTITY	13 INCH REEL QUANTITY
D-PAK	16	80	-----	2500
D ² -PAK	24	-----	-----	800
DFN-10	8	-----	3000	-----
GLASS MELF	12	-----	-----	5000
LMBS-1	12	-----	-----	5000
MBS-1	12	-----	-----	3000
MELF	12	-----	-----	5000
MINIMELF	8	-----	2500	-----
MICROMELF	8	-----	2500	-----
QUADRO MELF	8	-----	2500	-----
HSMA	12	-----	-----	3000
HSMB	12	-----	-----	3000
HSMC	16	-----	-----	1500
SDB-1	16	50	-----	1500
SMAE	12	-----	-----	6000
DO-221AC	12	-----	-----	10000
SMA	12	-----	-----	5000
SMB	12	-----	-----	3000
SMC	16	-----	-----	3000
SOD-123/323/323FL	8	-----	3000	-----
SOD-123FL	8	-----	2500	-----
SOD-523/723/923	8	-----	8000	-----
SOD-882	8	-----	10000	-----
SOT-143	8	-----	3000	-----
SOT-23	8	-----	3000	-----
SOT-23-6L	8	-----	3000	-----
SOT-223	12	-----	-----	2500
SOT-323/523	8	-----	3000	-----
SOT-353/363/563/553	8	-----	3000	-----
SOT-723	8	-----	8000	-----
SOT-89	12	-----	1000	-----
TO-277B	12	-----	-----	5000

Note 1: These are minimum package quantities only. Minimum orders will differ. Contact the factory for more information on minimum order quantities.

Note 2: MCC Tape&reel products meets EIA-481 REV D specification.

TAPE DIMENSIONS AND ORIENTATION

(in millimeters)

8mm Tape

SOT-23/323/523/723

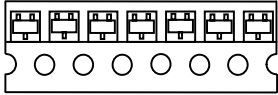

MICROMELF / MINIMELF

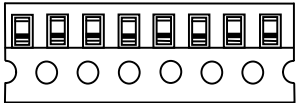

SOD-123/323/323FL/523
/723/923

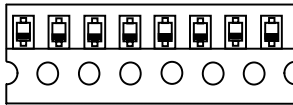

SOT-23-6L/363/563

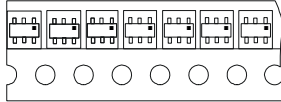

SOT-143

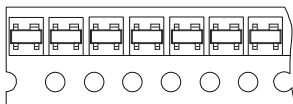

12mm Tape

MELF, GLASSMELF

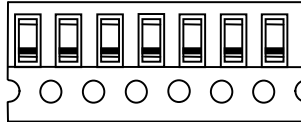

SMA / SMB/DO-221AC

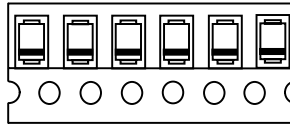

MBS-1, LMBS-1

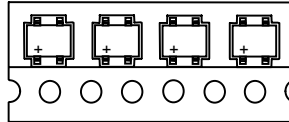

SOT-89/223

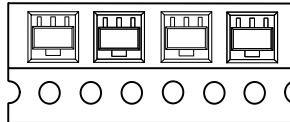

TO-277B

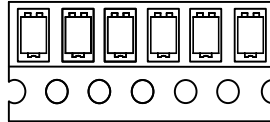

16mm Tape

SMC / HSMC

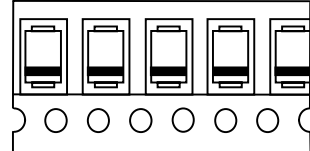

SDB-1

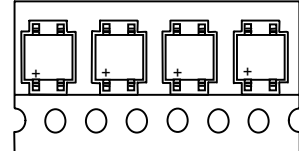

D-PAK

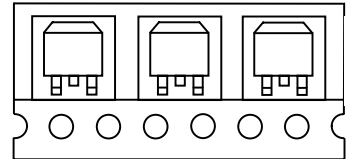

24mm Tape

D²-PAK

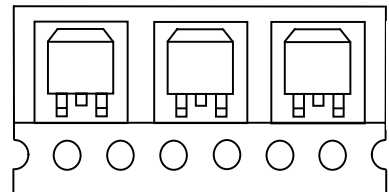

DIRECTION OF UNREELING



SURFACE MOUNT

Embossed Carrier Tape Specifications (8, 12, 16, 24mm Tape)

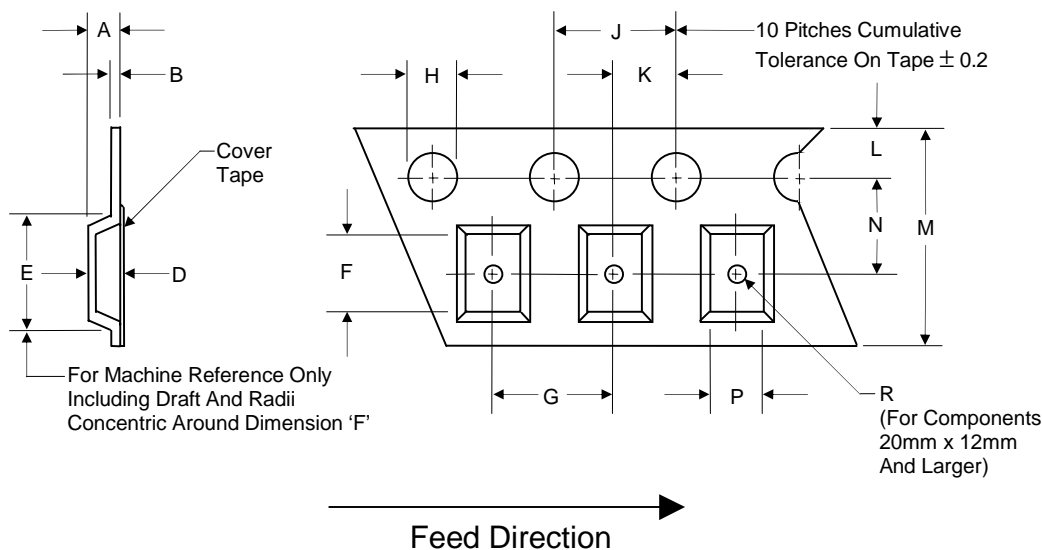

Tape Size	H	L	J	B (Max)	D, F, P	Constant Dimensions
8,12,16,24	1.5 _{+0.1, -0.0}	1.75±0.10	4.0±0.1	0.600	See Note 1	

Tape Size	E (Max)	R (Min)	N	A (Max)	K	M	Variable Dimensions
8mm	4.2	1.0	3.5±0.05	2.4	2.0±0.05	8.0±0.30	
12mm	8.2	1.5	5.5±0.05	4.5	2.0±0.05	12.0±0.30	
16mm	12.1	1.5	7.5±0.10	6.5	2.0±0.10	16.0±0.30	
24mm	20.1	1.5	11.5±0.10	11.9	2.0±0.10	24.0±0.30	

Tape Size	G				
	2.0±0.10	4.0±0.10	8.0±0.10	12.0±0.10	16.0±0.10
8mm	X	X			
12mm		X	X		
16mm		X	X	X	
24mm					X

Note: D, F, P are determined by constant size. The clearance between the part and the tape cavity must be within 0.05mm min. to 0.50mm max. for 8mm tape, 0.05mm min. to 0.65mm max. for 12mm tape and 0.05mm min. to 0.90mm max. for 16mm tape.

SURFACE MOUNT

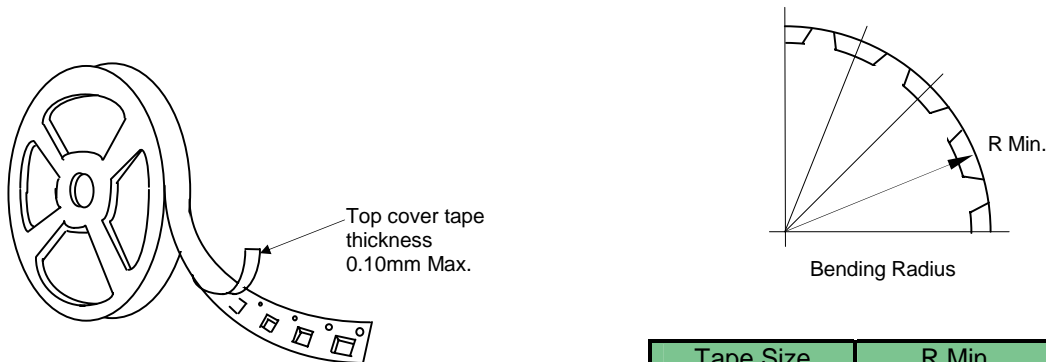

Tape Size	R Min.
8mm	25mm
12mm	30mm
16mm	30mm
24mm	30mm

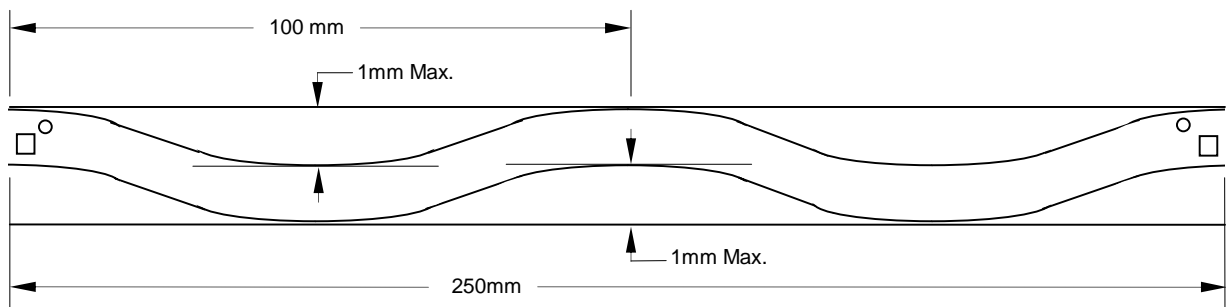

Camber (Top View)

Allowable camber to be 1mm/100mm non-accumulative over 250mm

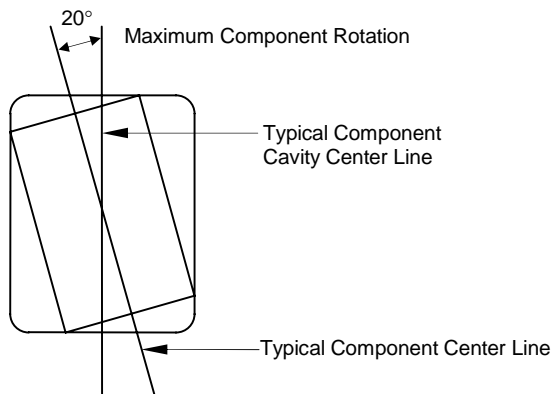

SURFACE MOUNT

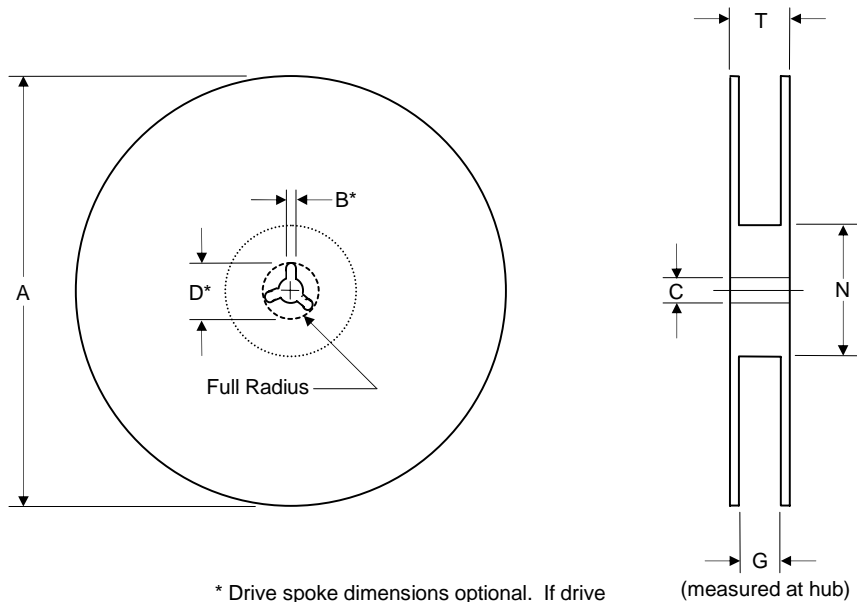

* Drive spoke dimensions optional. If drive spoke is used then asterisked dimensions apply.

Tape Size	A Max.	B* Min.	C	D* Max.	N Min.	G	T Max.
8mm	330	1.5	13.0±0.20	20.2	55	8.4 ^(+1.5/-0.0)	14.4
12mm	330	1.5	13.0±0.20	20.2	55	12.4 ^(+2.0/-0.0)	18.4
16mm	360	1.5	13.0±0.20	20.2	55	16.4 ^(+2.0/-0.0)	22.4
24mm	360	1.5	13.0±0.20	20.2	55	24.4 ^(+2.0/-0.0)	30.4

Start And Finish Specifications

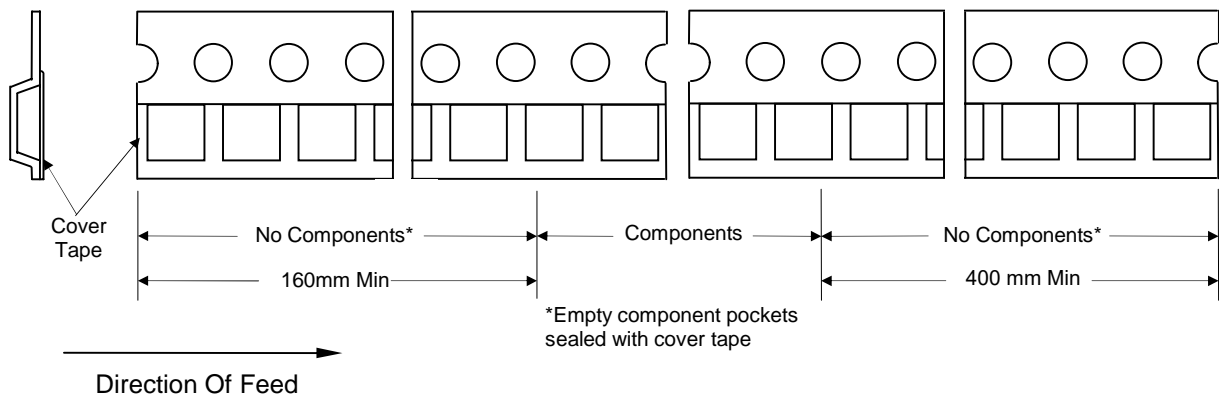

RADIAL TAPING SPECIFICATIONS **FOR RECTIFIERS**

A-405 Outline Only

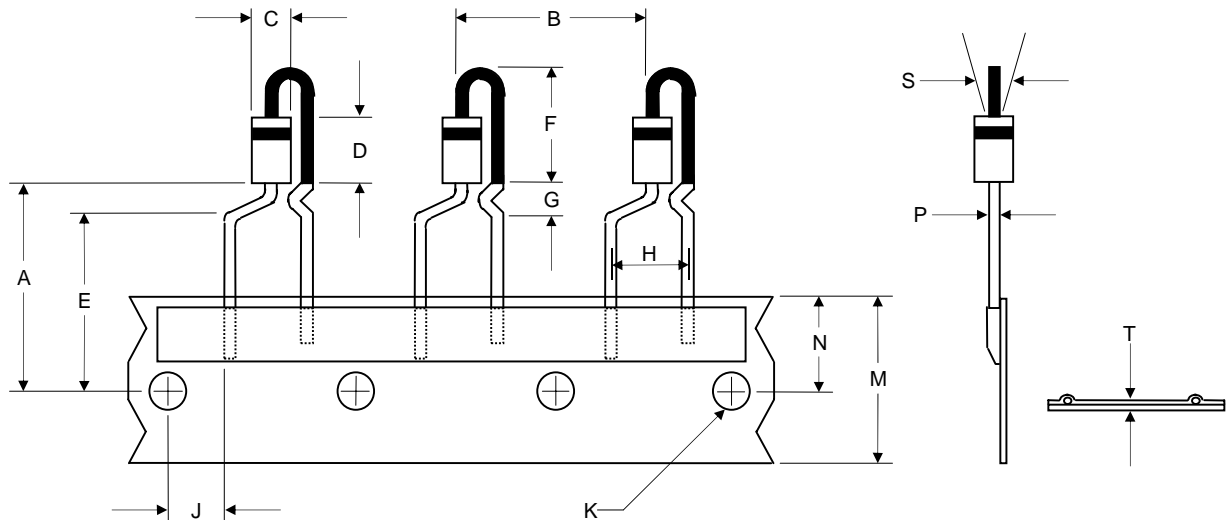

DIMENSIONS					
DIM	INCHES		MM		NOTE
	MIN	MAX	MIN	MAX	
A	.709	.748	18.0	20.0	
B	.460	.540	11.7	13.7	
C	---	.106	---	2.7	
D	---	.205	---	5.2	
E	.610	.650	15.5	16.5	
F	---	.354	---	9.0	
G	---	.177	---	4.5	
H	.177	.217	4.5	5.5	
J	.124	.179	3.15	4.55	
K	.146	.169	3.7	4.3	
M	.677	.748	17.2	19.0	
N	.343	.384	8.70	9.75	
P	.021	.025	.54	.64	
S	---	±.079	---	±2.0	
T	.016	.031	.4	.8	

PACKING METHODS

P/N EXAMPLE: A=N: PANASERT
A B C

- B = 0: NON INSULATION COATING---
LEAD FIRST OUT.
1: INSULATION COATING---
LEAD FIRST OUT.
2: NON INSULATION COATING---
BODY FIRST OUT.
3: INSULATION COATING---
BODY FIRST OUT.

- C = 1: FOR CATHODE DOWN,
IN BULK.
2: FOR CATHODE UP,
IN BULK.
3: FOR CATHODE DOWN,
IN REEL.
4: FOR CATHODE UP,
IN REEL

RADIAL TAPING SPECIFICATIONS **FOR RECTIFIERS**

A-405 Outline Only

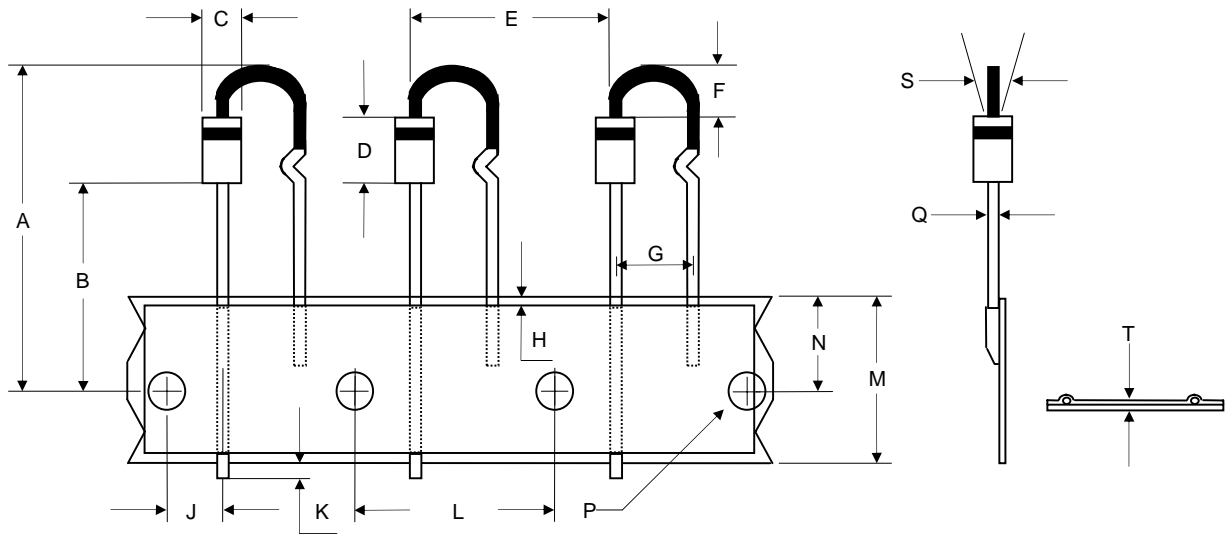

DIMENSIONS					
DIM	INCHES		MM		NOTE
	MIN	MAX	MIN	MAX	
A	.905	1.26	23.0	32.0	
B	.630	---	16.0	---	
C	---	.106	---	2.7	
D	---	.205	---	5.2	
E	.460	.540	11.7	13.7	
F	---	.098	---	2.5	
G	.193	.213	4.9	5.4	
H	---	.118	---	3.0	
J	.124	.179	3.15	4.55	
K	---	.079	---	2.0	
L	.488	.512	12.4	13.0	
M	.677	.748	17.2	19.0	
N	.343	.384	8.70	9.75	
P	.146	.169	3.7	4.3	
Q	.021	.025	.54	.64	
S	---	±.079	---	±2.0	
T	.016	.031	.4	.8	

PACKING METHODS

P/N EXAMPLE: A=V:AVISERT
A B

- B = 1: INSULATION COATING/
LEAD FIRST OUT/ CATHODE UP/
IN REEL
- 2: INSULATION COATING/
BODY FIRST OUT/CATHODE UP/
IN REEL..
- 3: INSULATION COATING/
LEAD FIRST OUT/CATHODE DOWN/
IN REEL.
- 4: INSULATION COATING/
BODY FIRST OUT/
CATHODE DOWN/ IN REEL