

## Mechanical Data

- Surface Mount Package
- Weight: 0.0280 grams (Approximate)
- Moisture Sensitivity Level Refer to Product Datasheet
- Halogen Free. "Green" Device (Note 1)
- Epoxy Meets UL 94 V-0 Flammability Rating
- Lead Free Finish/RoHS Compliant (Note2) ("P" Suffix Designates RoHS Compliant. See Ordering Information)

Note:1. free "Green" products are defined as those which contain <900ppm bromine, <900ppm chlorine (<1500ppm total Br + Cl) and <1000ppm antimony compounds.  
2. High Temperature Solder Exemption Applied, see EU Directive Annex 7a.

## Package 3D Photo

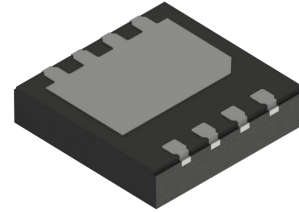

## Package Outline Dimensions

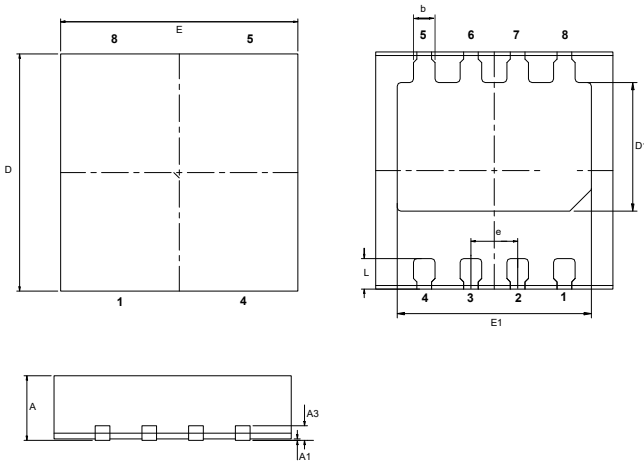

DIM	DIMENSIONS				NOTE
	INCHES		MM		
	MIN	MAX	MIN	MAX	
A	0.028	0.031	0.70	0.80	
A1	0.000	0.002	0.00	0.05	
A3	0.008		0.20		TYP.
b	0.010	0.014	0.25	0.35	
D	0.130		3.30		TYP.
E	0.130		3.30		TYP.
e	0.026		0.65		TYP.
D1	0.066	0.074	1.69	1.89	
E1	0.102	0.110	2.60	2.80	
L	0.013	0.021	0.325	0.525	

## Suggested Solder Pad Layout

Unit:mm

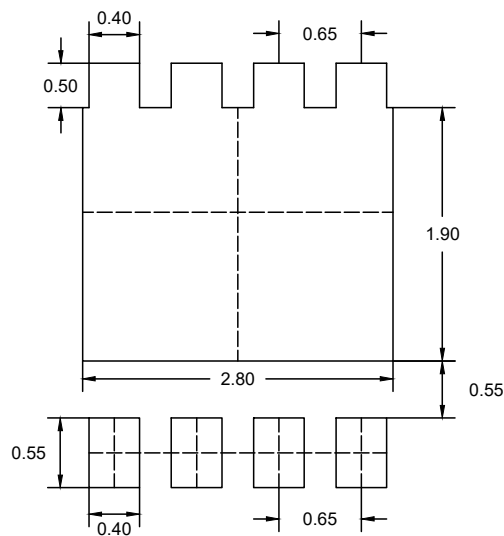

**Notes:**

- 1.The suggested land pattern dimensions have been provided for reference only.
- 2.For further information,please reference document IPC-7351A.

**Packing Quantity**

Package	Tape Width (mm)	Reel Size (inch)	Reel Quantity	BOX Quantity	Carton Quantity
DFN3333-8(SWF)	12	13	5000	10K	50K

Note 1: These are minimum package quantities only. Minimum orders will differ. Contact the factory for more information on minimum order quantities.

Note 2: MCC Tape&reel products meets EIA-481 REV D specification.

**Device Tape Orientation**

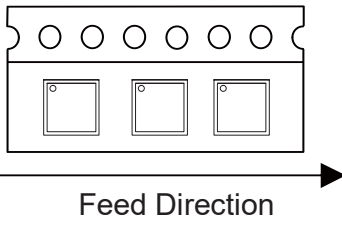
Package	Tape Width (mm)	Tape Orientation
DFN3333-8(SWF)	12	

**Embossed Carrier Tape Specifications**

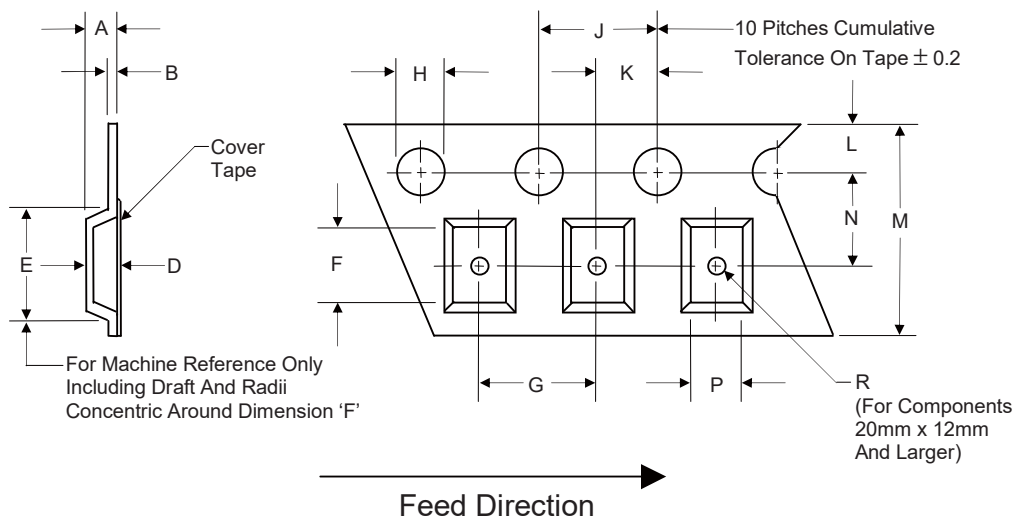

Tape Width	H	L	J	B	D	F	P
12mm	1.5	1.75	4.0	0.6	See Note 3		
(Tolerance)	+0.1/-0	±0.1	±0.1	Max			

Tape Width	E	R	N	A	K	M	G
12mm	8.2	1.5	5.5	4.5	2.0	12.0	8.0
(Tolerance)	Max	Min	±0.05	Max	±0.05	±0.3	±0.1

Note 3: D,E,F are determined by constant size. The clearance between the part and the tape cavity must be within 0.05mm min. to 0.65mm max. for 12mm tape.

## Embossed Carrier Tape Specifications



Tape Size	R Min.
12mm	30mm

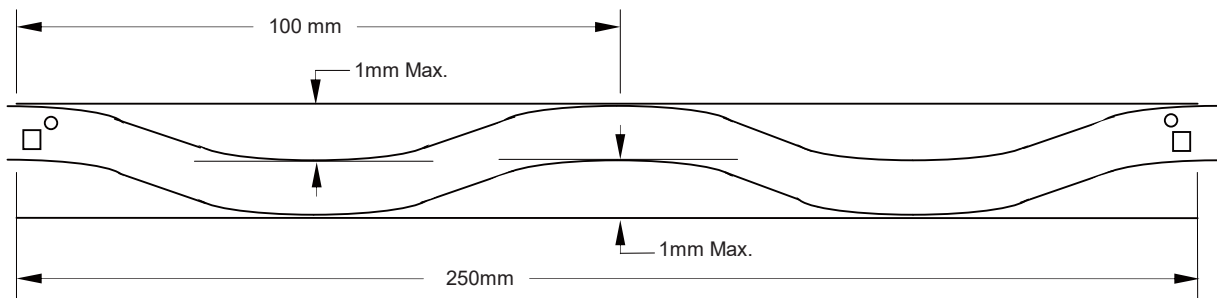

Camber (Top View)

Allowable camber to be 1mm/100mm non-accumulative over 250mm

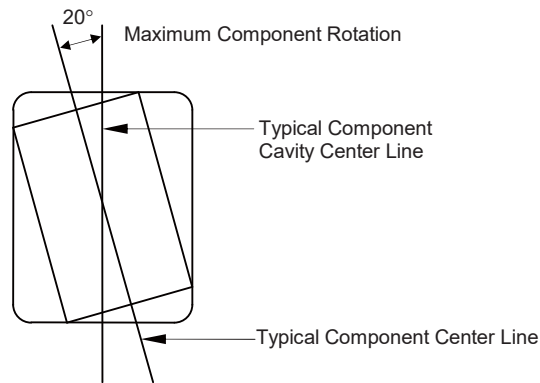

## Start and Finish Specification

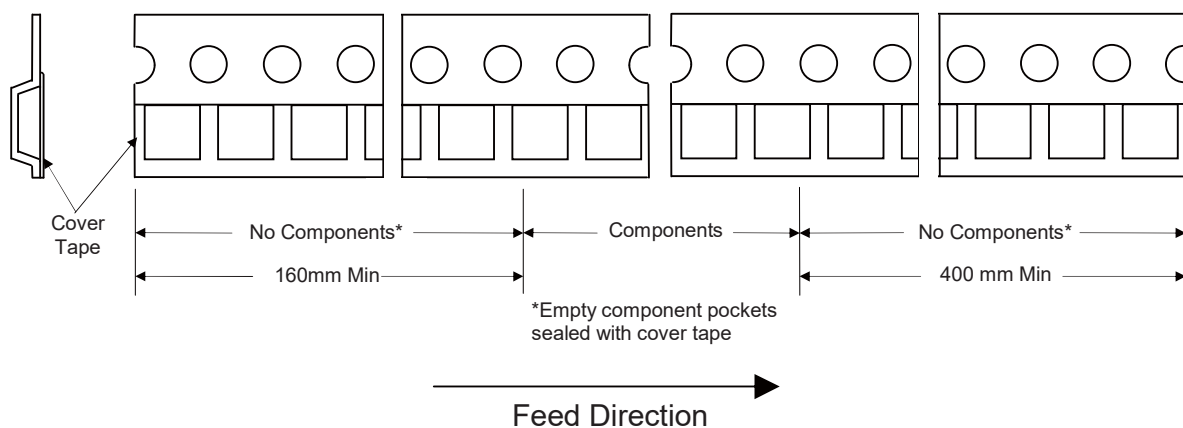

## Surface Mount Reel Specifications

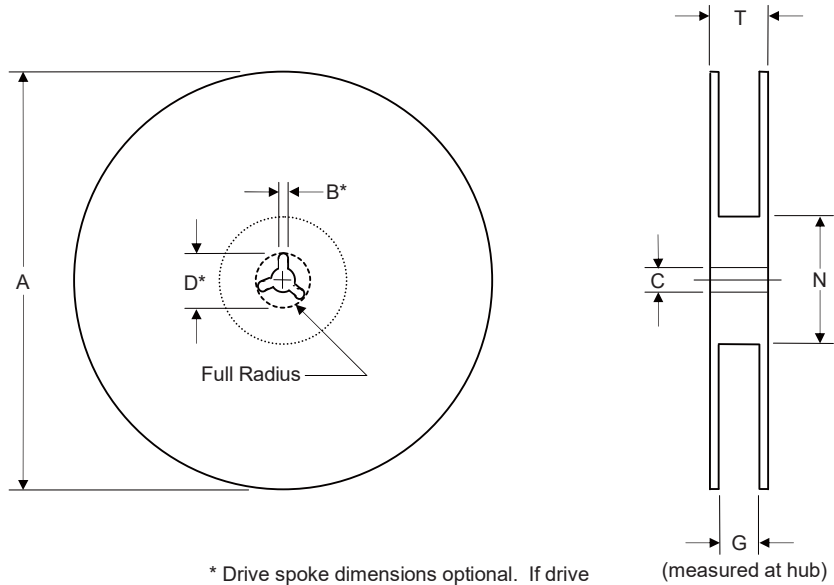

\* Drive spoke dimensions optional. If drive spoke is used then asterisked dimensions apply.

Tape Width	A	B	C	D	N	G	T
12mm	330	1.5	13.0	20.2	55	12.4	18.4
(Tolerance)	±2.0	Min	±0.2	Min	Min	+2.0	Max

## Dimensions

### Inbox Size

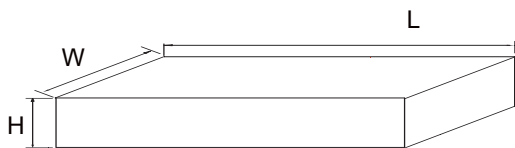

Description	Dimension	Specification(mm typical)
Length	L	370
Width	W	340
Height	H	55

### Carton Size

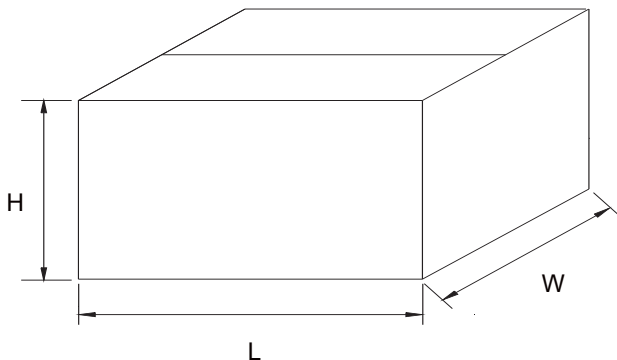

Description	Dimension	Specification(mm typical)
Length	L	385
Width	W	365
Height	H	315