

**Mechanical Data**

- Surface Mount Package
- Weight: 2.86 grams (Approximate)
- Moisture Sensitivity Level 1
- Halogen Free Available Upon Request By Adding Suffix "-HF"
- Epoxy Meets UL 94 V-0 Flammability Rating
- Lead Free Finish/RoHS Compliant <sup>(Note1)</sup> ("P" Suffix Designates RoHS Compliant. See Ordering Information)

Note: 1. High Temperature Solder Exemption Applied, see EU Directive Annex 7a.

**Package 3D Photo**

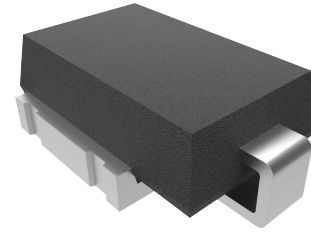

**Package Outline Dimensions**

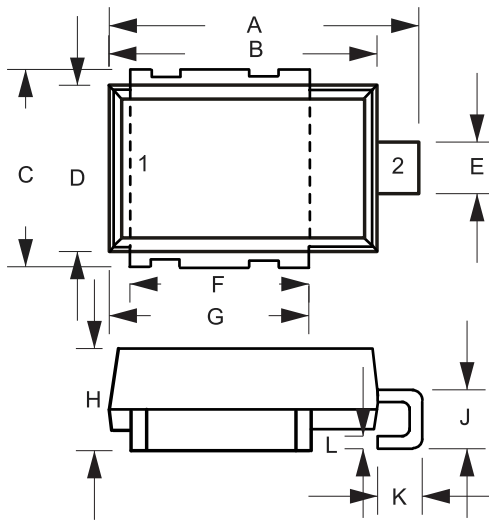

DIM	DIMENSIONS				NOTE
	INCHES		MM		
	MIN	MAX	MIN	MAX	
A	0.590	0.630	15.00	16.00	
B	0.524	0.539	13.30	13.70	
C	0.374	0.413	9.50	10.50	
D	0.323	0.339	8.20	8.60	
E	0.091	0.114	2.30	2.90	
F	0.343	0.366	8.70	9.30	
G	0.382	0.406	9.70	10.30	
H	0.189	0.205	4.80	5.20	
J	0.098	0.138	2.50	3.50	
K	0.067	0.106	1.70	2.70	
L	0.020	0.028	0.50	0.70	

**Suggested Solder Pad Layout**

Unit:mm

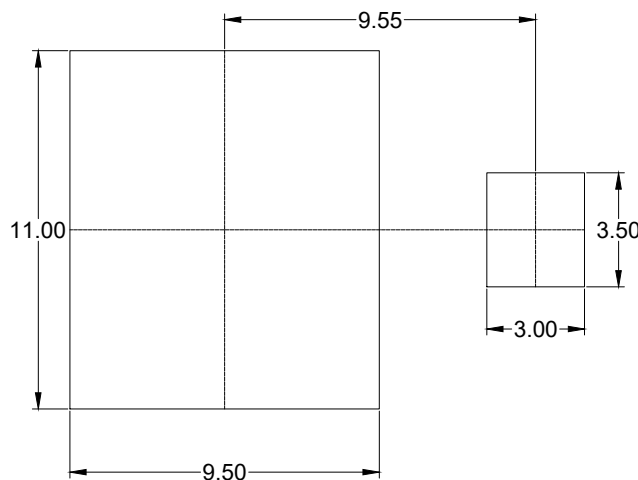

Notes:

- 1.The suggested land pattern dimensions have been provided for reference only.
- 2.For further information,please reference document IPC-7351A.

**Packing Quantity**

Package	Tape Width (mm)	Reel Size (inch)	Reel Quantity	BOX Quantity	Carton Quantity
DO-218AB	24	13	750	750	3750

Note 1: These are minimum package quantities only. Minimum orders will differ. Contact the factory for more information on minimum order quantities.

Note 2: MCC Tape&reel products meets EIA-481 REV D specification.

**Device Tape Orientation**

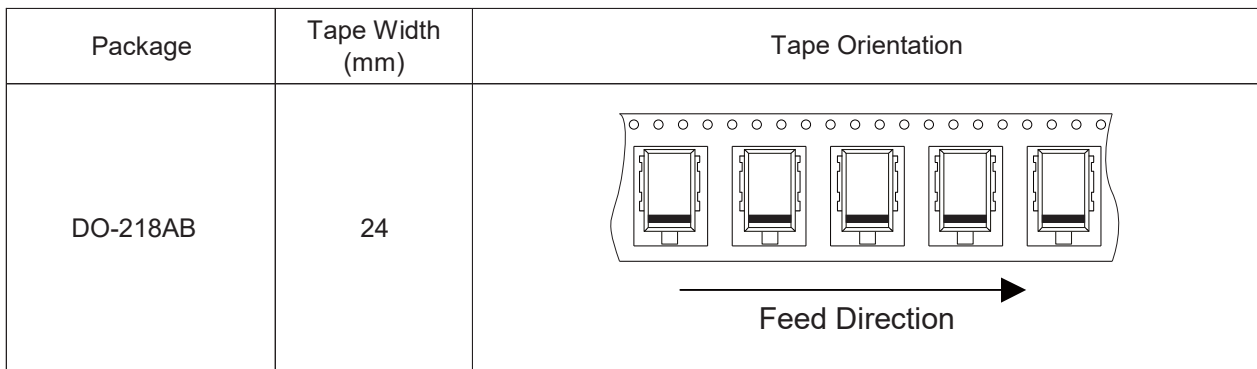

**Embossed Carrier Tape Specifications**

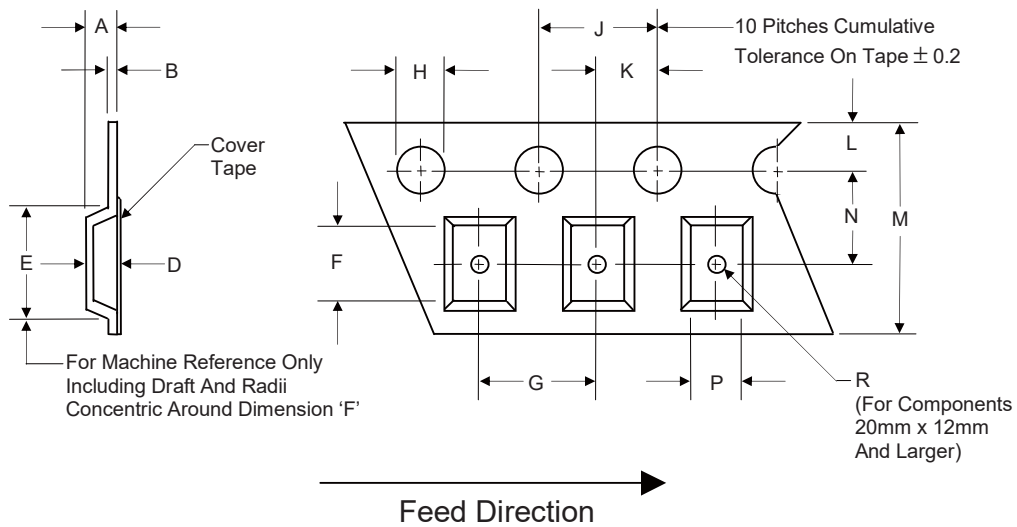

Tape Width	H	L	J	B	D	F	P
24mm	1.5	1.75	4.0	0.6	See Note 3		
(Tolerance)	+0.1/-0	±0.1	±0.1	Max			

Tape Width	E	R	N	A	K	M	G
24mm	20.1	1.5	11.5	11.9	2.0	24.0	16.0
(Tolerance)	Max	Min	± 0.10	Max	± 0.10	±0.3	±0.1

Note 3: D,E,F are determined by constant size. The clearance between the part and the tape cavity must be within 0.05mm min. to 1.20mm max. for 24mm tape.

## Embossed Carrier Tape Specifications

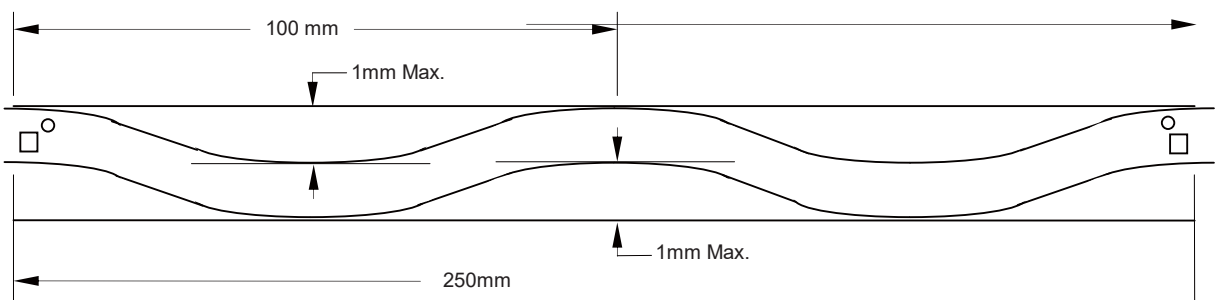

Camber (Top View)

Allowable camber to be 1mm/100mm non-accumulative over 250mm

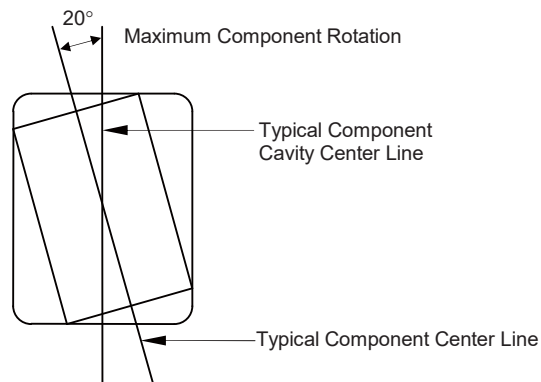

## Start and Finish Specification

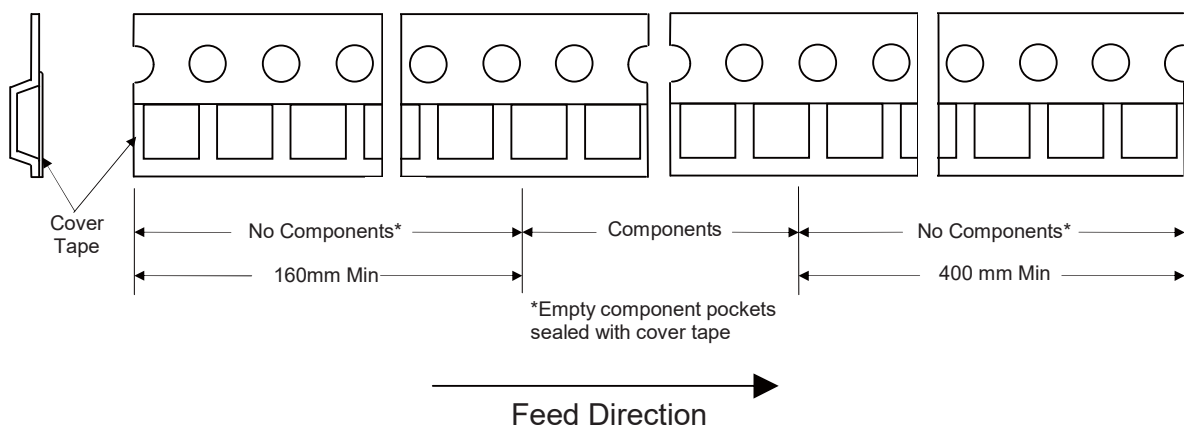

## Surface Mount Reel Specifications

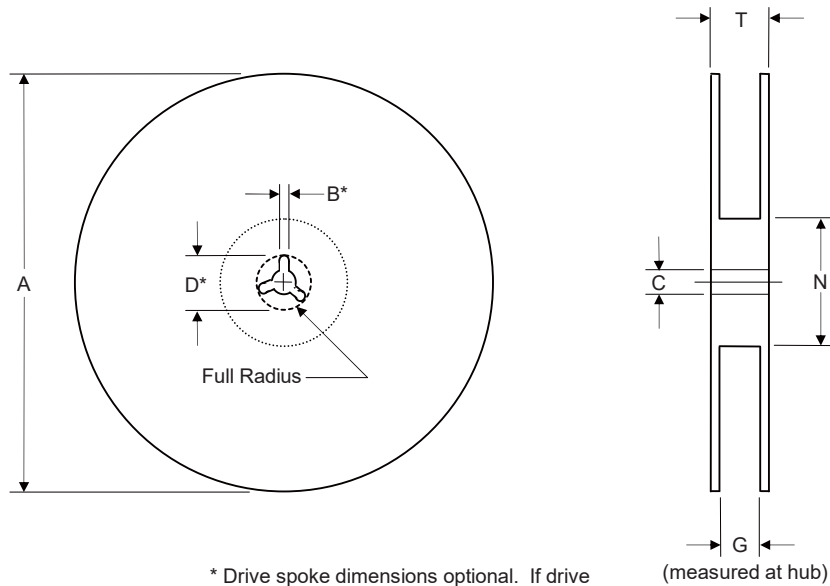

\* Drive spoke dimensions optional. If drive spoke is used then asterisked dimensions apply.

Tape Width	A	B	C	D	N	G	T
24mm	360	1.5	13.0	20.2	55	24.4	30.4
(Tolerance)	Max	Min	±0.2	Min	Min	+2.0	Max

## Dimensions

### Inbox Size

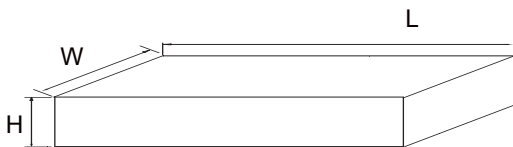

Description	Dimension	Specification(mm typical)
Length	L	355
Width	W	340
Height	H	35

### Carton Size

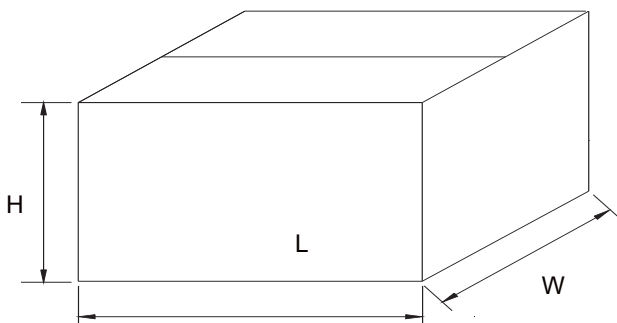

Description	Dimension	Specification(mm typical)
Length	L	365
Width	W	350
Height	H	180