

Mechanical Data

- Surface Mount Package
- Weight: 0.072 grams (Approximate)
- Moisture Sensitivity Level 1
- Halogen Free Available Upon Request By Adding Suffix "-HF"
- Epoxy Meets UL 94 V-0 Flammability Rating
- Lead Free Finish/RoHS Compliant ^(Note1) ("P" Suffix Designates RoHS Compliant. See Ordering Information)

Note: 1. High Temperature Solder Exemption Applied, see EU Directive Annex 7a.

Package 3D Photo

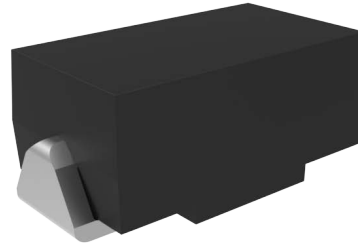

Package Outline Dimensions

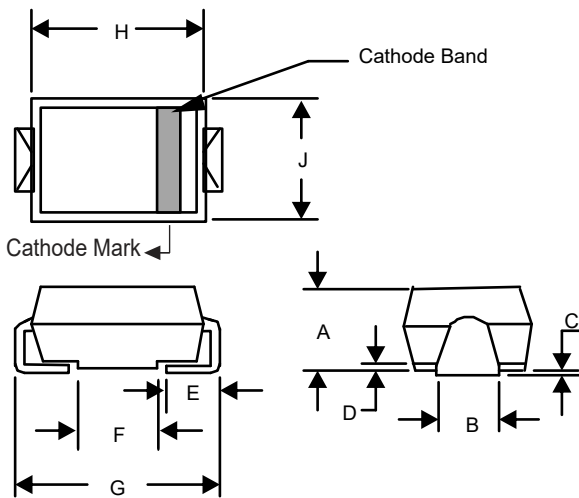

DIM	INCHES		MM		NOTE
	MIN	MAX	MIN	MAX	
A	0.079	0.096	2.01	2.44	
B	0.045	0.071	1.15	1.80	
C	0.002	0.008	0.05	0.20	
D	---	0.020	---	0.51	
E	0.030	0.060	0.76	1.52	
F	0.065	0.084	1.65	2.13	
G	0.189	0.208	4.80	5.30	
H	0.157	0.180	4.00	4.57	
J	0.090	0.115	2.29	2.92	

Suggested Solder Pad Layout

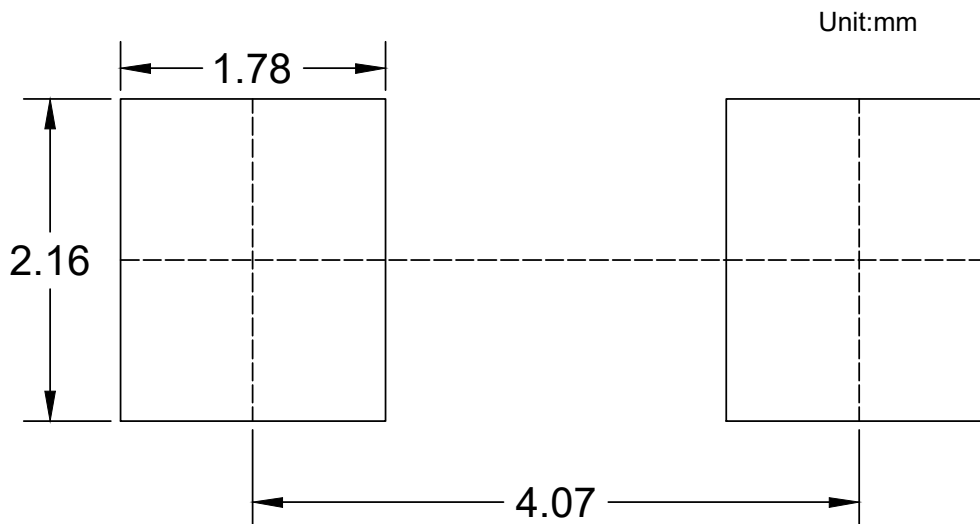

Notes:

- 1.The suggested land pattern dimensions have been provided for reference only.
- 2.For further information,please reference document IPC-7351A.

Packing Quantity

Package	Tape Width (mm)	Reel Size (inch)	Reel Quantity	Carton Quantity
SMAE	12	13	6000	96K

Note 1: These are minimum package quantities only. Minimum orders will differ. Contact the factory for more information on minimum order quantities.

Note 2: MCC Tape&reel products meets EIA-481 REV D specification.

Device Tape Orientation

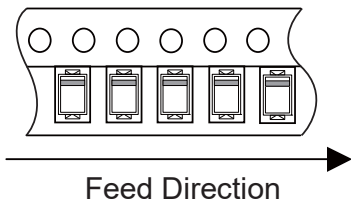
Package	Tape Width (mm)	Tape Orientation
SMAE	12	

Embossed Carrier Tape Specifications

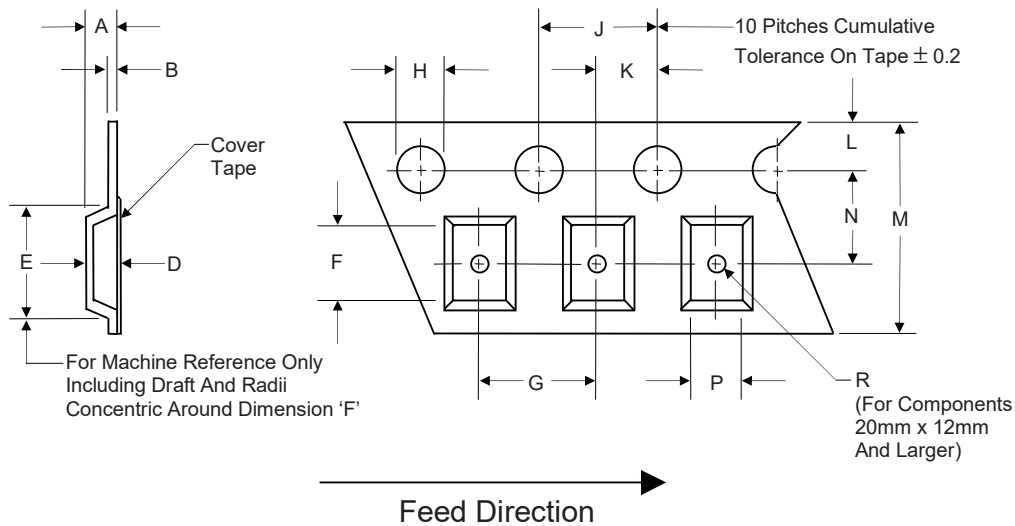

Tape Width	H	L	J	B	D	F	P
12mm	1.5	1.75	4.0	0.6	See Note 3		
(Tolerance)	+0.1/-0	±0.1	±0.1	Max			

Tape Width	E	R	N	A	K	M	G
12mm	8.2	1.5	5.5	4.5	2.0	12.0	4.0
(Tolerance)	Max	Min	±0.05	Max	±0.05	±0.3	±0.1

Note 3: D,E,F are determined by constant size. The clearance between the part and the tape cavity must be within 0.05mm min. to 0.65mm max. for 12mm tape.

Embossed Carrier Tape Specifications

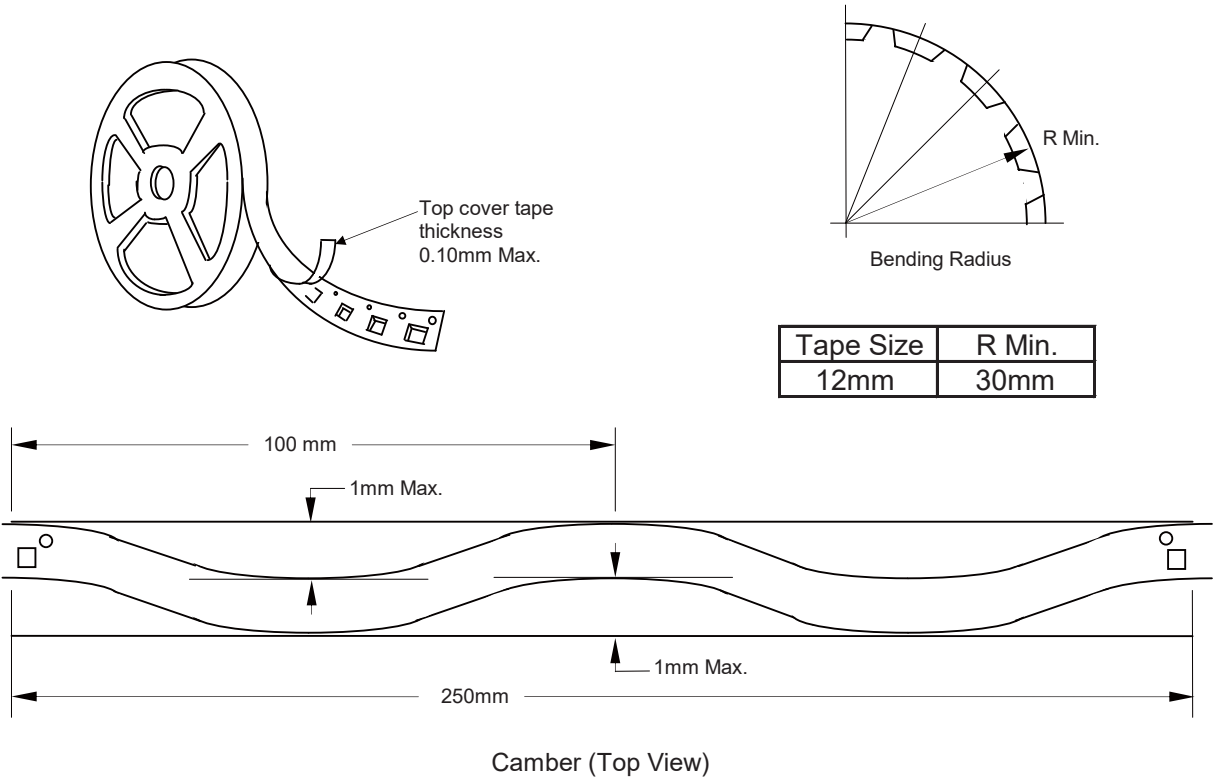

Allowable camber to be 1mm/100mm non-accumulative over 250mm

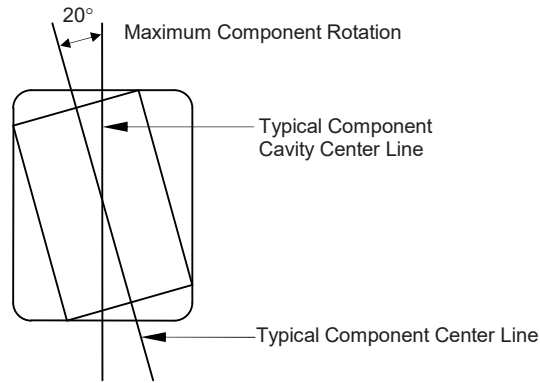

Start and Finish Specification

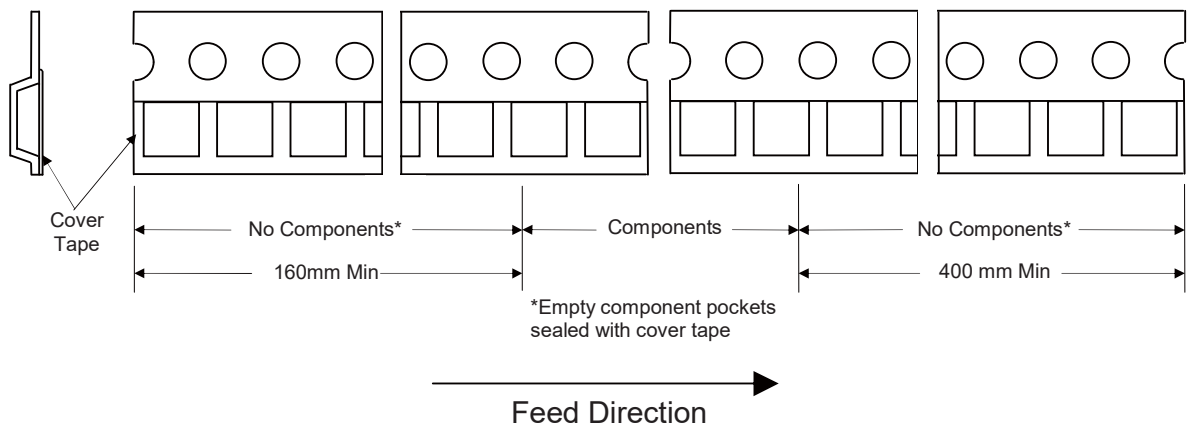

Surface Mount Reel Specifications

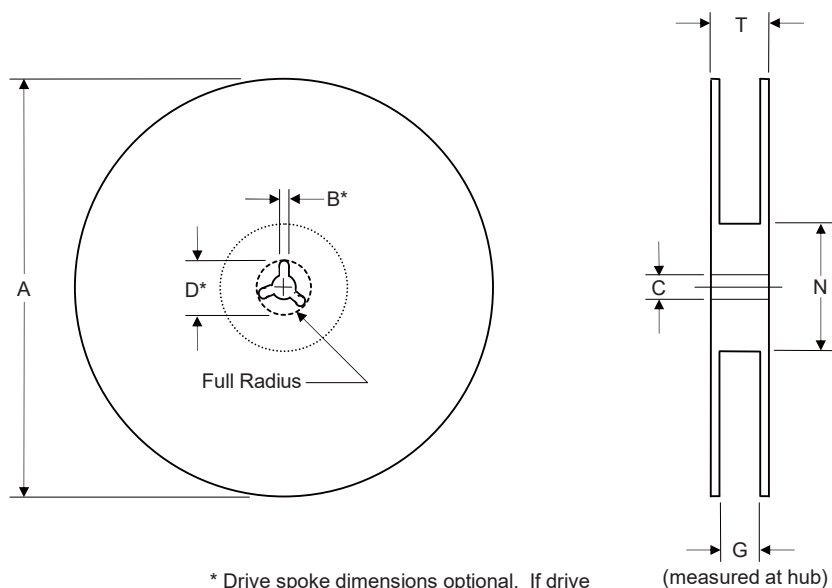

* Drive spoke dimensions optional. If drive spoke is used then asterisked dimensions apply.

Tape Width	A	B	C	D	N	G	T
12mm	330	1.5	13.0	20.2	55	12.4	18.4
(Tolerance)	±2.0	Min	±0.2	Min	Min	+2.0	Max

Dimensions

Carton Size

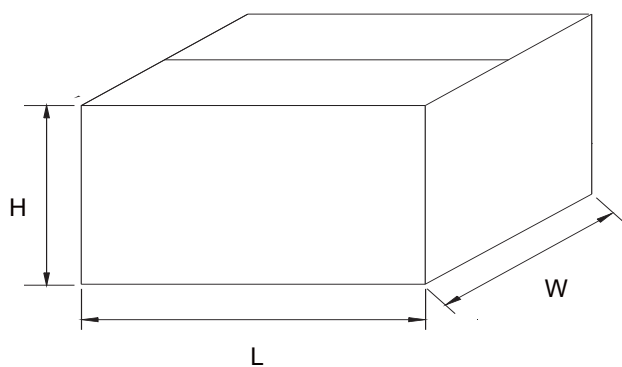

Description	Dimension	Specification(mm typical)
Length	L	355
Width	W	345
Height	H	290